



























## Fabricated Steel Sprockets

Sprockets are fabricated from high carbon steel and are available in Solid, Split, Removable Rim or Split Removable Rim. All surfaces that contact the chain are hardened.

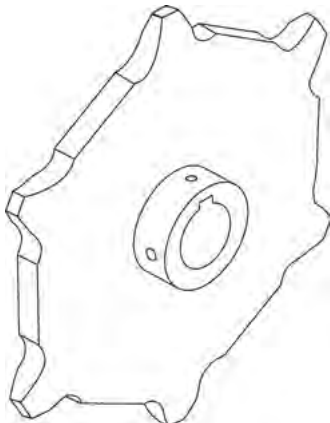

*Solid*

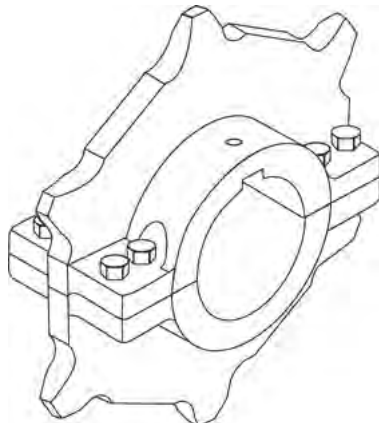

*Split*

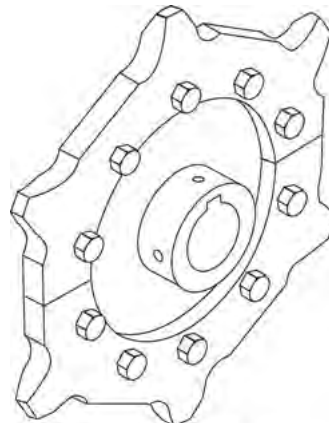

*Removable Rim*

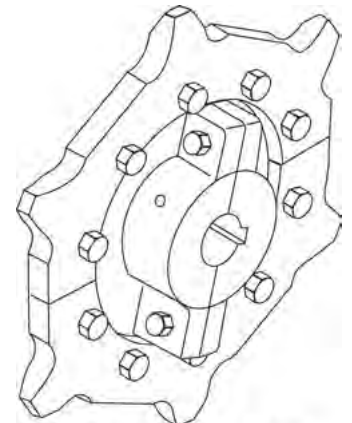

*Split Removable Rim*

# TEETH & PITCH DIAMETER

Chain Size	3	4	5	6	7	8	9
X-348	6.00"	7.83"	9.71"	11.59"	-	-	17.28"
458/X458	8.00"	10.45"	12.94"	15.45"	17.97"	20.50"	23.03"
468	-	10.45"	12.94"	15.45"	17.97"	20.50"	23.03"
658	-	15.68"	19.41"	23.18"	26.96"	30.75"	34.56"
678/X678	-	15.68"	19.41"	23.18"	26.96"	30.75"	34.56"
698	-	15.68"	19.41"	23.18"	26.96"	30.75"	34.56"
998	-	23.52"	29.12"	34.77"	40.45"	46.13"	-
9118	-	23.52"	29.12"	34.77"	40.45"	-	-
9148	-	23.52"	29.12"	34.77"	40.45"	-	-



**WILMOT**  
**COMPANY, INC.**

Sales: 888.594.5668 | Fax: 570.636.5252 | [sales@wilmotco.com](mailto:sales@wilmotco.com)  
545 Hazle Street, Freeland, PA 18224 | [www.wilmotco.com](http://www.wilmotco.com)

© 2017 Wilmot Company, Inc. All rights reserved.  
Layout and design by Bradley Brown Design Group, Inc.  
[www.bradleybrowndesign.com](http://www.bradleybrowndesign.com)